



WITTENSTEIN

alpha

# Lubricator

Operating Manual

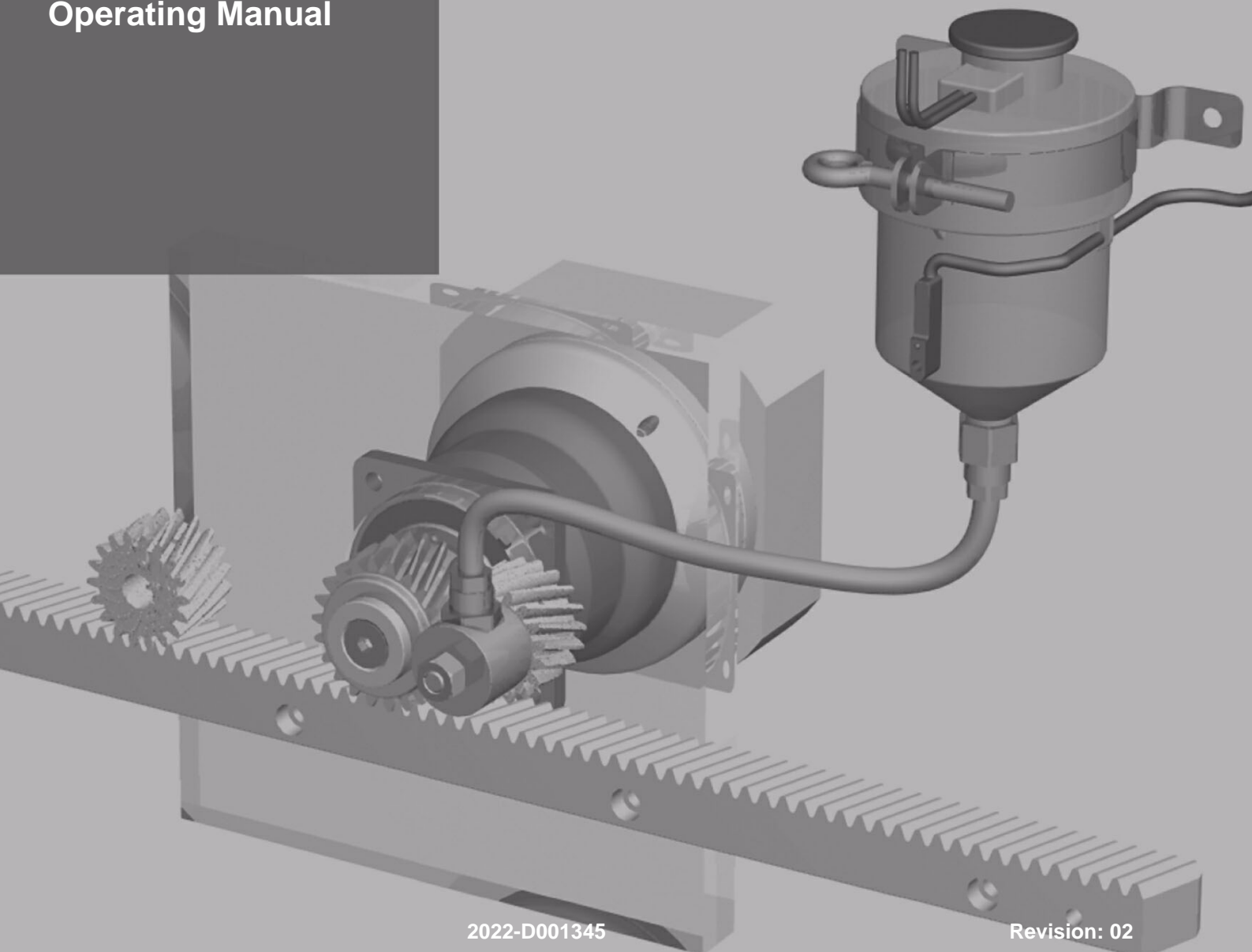

## Revision history

Revision	Date	Comment	Chapter
01	23.08.01	New version	All
02	22.04.09	Technical Data updated, Layout WITTENSTEIN	All

### Service

In case you have technical questions, please contact:

#### **WITTENSTEIN alpha GmbH**

Customer Service  
Walter-Wittenstein-Straße 1  
D-97999 Igersheim

Tel.: +49 7931 493-10900

Fax: +49 7931 493-10903

E-mail: [service-alpha@wittenstein.de](mailto:service-alpha@wittenstein.de)

### © WITTENSTEIN alpha GmbH 2009

This documentation is copyright protected.

**WITTENSTEIN alpha GmbH** reserves all the rights to photo-mechanical reproduction, copying, and the distribution by special processes (such as computers, file media, data networks), even in parts.

Subject to technical and content changes without notice.

## Contents

<b>1</b>	<b>On this manual .....</b>	<b>3</b>
1.1	Signal words .....	3
1.2	Safety symbols.....	3
1.3	Design of the safety instructions .....	4
1.4	Information symbols.....	4
<b>2</b>	<b>Safety.....</b>	<b>5</b>
2.1	EC – Machinery directive .....	5
2.2	Dangers .....	5
2.3	Personnel.....	5
2.4	Intended use .....	5
2.5	Reasonably predictable misuse .....	5
2.6	Guarantee and liability .....	5
2.7	General safety instructions .....	6
<b>3</b>	<b>Description of the lubricator .....</b>	<b>7</b>
3.1	Functional principle of the lubricator .....	7
3.2	Overview of the lubricator components.....	7
3.3	Type plate .....	8
3.4	Notes on the lubricant used .....	9
3.5	Notes on the employed batteries .....	9
3.6	Technical specifications .....	10
3.6.1	Technical specifications of the lubricator.....	10
3.6.2	Technical specifications magnetic field sensor .....	10
<b>4</b>	<b>Transport and storage .....</b>	<b>11</b>
4.1	Scope of delivery .....	11
4.2	Packaging .....	11
4.3	Transport.....	11
4.4	Storage .....	11
<b>5</b>	<b>Assembly .....</b>	<b>12</b>
5.1	Preparations.....	12
5.2	Mounting the lubricator .....	12
5.3	Synchronization with the machine runtime .....	13
5.3.1	Employing the lubricator with synchronization .....	13
5.3.2	Employing the lubricator without synchronization .....	13
5.4	Installation of the magnetic field sensor for detecting the end position.....	14
<b>6</b>	<b>Startup and operation .....</b>	<b>15</b>
6.1	Activating the lubricator.....	15
6.2	Setting the lubrication duration .....	16
6.3	Restarting after a shutdown .....	16
<b>7</b>	<b>Maintenance and disposal.....</b>	<b>17</b>
7.1	Maintenance work.....	17
7.1.1	Visual inspection .....	17
7.1.2	Cleaning .....	17
7.2	Maintenance schedule .....	17
7.3	Replacing the lubricator .....	17
7.4	Disposing of the lubricator .....	18
<b>8</b>	<b>Malfunctions .....</b>	<b>19</b>
<b>9</b>	<b>Appendix.....</b>	<b>20</b>
9.1	Setting combinations for lubricator.....	20
9.2	Lubrication aids.....	21
9.2.1	Lubrication aid I for type 125.....	21
9.2.2	Lubrication aid II for type 125.....	21
9.2.3	Lubrication aid III .....	21

9.3 Installation dimensions pipe clamp for lubricator.....	22
9.4 Spare parts list .....	22

## 1 On this manual

These instructions contain necessary information for the safe operation of the lubricator and the components.

The operator must make sure that this operating manual is read through by all persons assigned to install, operate, or maintain the lubricator, and that they understand them.

Store these instructions within reach near the lubricator.

Please pass the safety instructions on to other persons as well.

### 1.1 Signal words

The following signal words are used to bring your attention to dangers, prohibitions, and important information:

	<b>⚠ DANGER</b>
	This signal word points out to an imminent danger that can cause serious injuries and even death.
	<b>⚠ WARNING</b>
	This signal word points out to a possible danger that can cause serious injuries and even death.
	<b>⚠ CAUTION</b>
	This signal word points out to a possible danger that can cause slight to serious injuries.
	<b>NOTICE</b>
	This signal word points out to a possible danger that can cause material damage.
	This signal word draws your attention to application tips or especially important information when handling the lubricator.

### 1.2 Safety symbols

The following safety symbols are used to bring your attention to dangers, prohibitions, and important information:



General danger



Environment protection



Information



Electrostatic discharge sensitive component

### 1.3 Design of the safety instructions

The safety instructions of this operating manual is designed according to the following pattern:

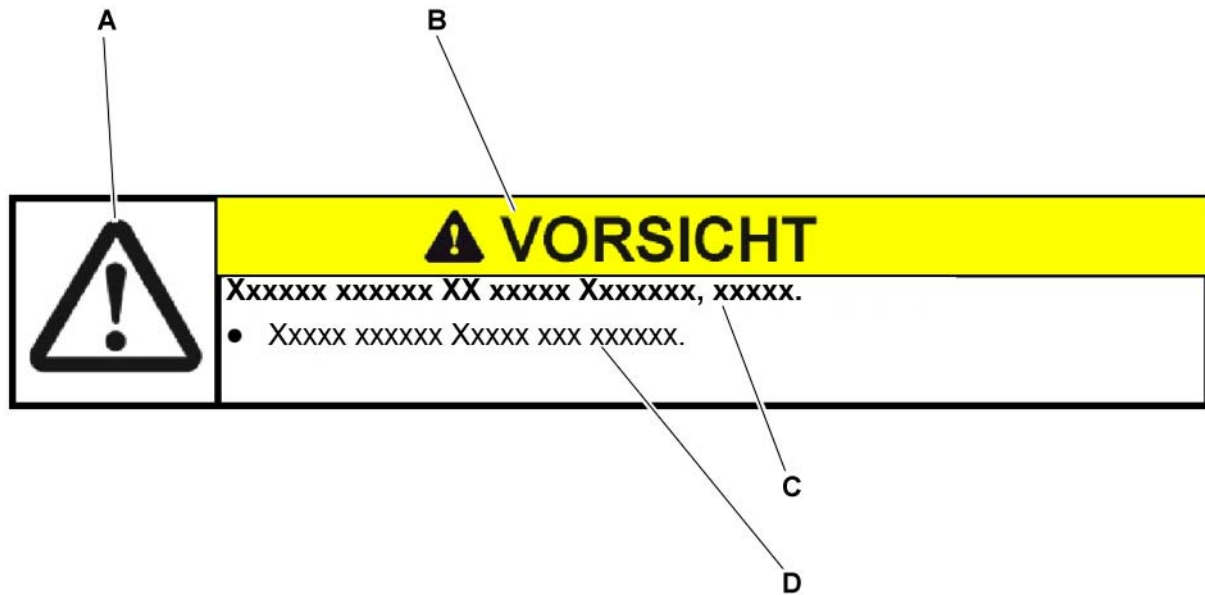

A = Safety symbol (see Chapter 1.2 "Safety symbols")

B = Signal word (see Chapter 1.1 "Signal words")

C = Type and consequence of the danger

D = Prevention of the danger

### 1.4 Information symbols

The following information symbols are used:

- requires you to carry out an action
- ➡ indicates the results of an action
- ⓘ provides additional information on handling

## 2 Safety

This operating manual, especially the safety instructions and the rules and regulations valid for the operating site, must be observed by all persons working with the lubricator.

In addition to the safety specifications mentioned in this operating manual, the general and also the local regulations on the prevention of accidents and on environmental protection should be observed.

### 2.1 EC – Machinery directive

Within terms of the EC machinery directive 2006/42/EC, the lubricator is considered a "machine".

### 2.2 Dangers

The lubricator has been constructed according to current technological standards and accepted safety regulations.

To avoid danger to the operator or damage to the machine, the lubricator may be put to use only for its intended usage (see Chapter 2.4 "Intended use") and in a technically flawless and safe state.

### 2.3 Personnel

Only persons may carry out work on the lubricator if they have read and understood this operating manual.

### 2.4 Intended use

The lubricator is an technical component that was developed to counter wear and tear and friction on machine components by targeted lubrication.

### 2.5 Reasonably predictable misuse



Any usage that exceeds the permitted ambient temperature is considered a misuse and is therefore prohibited.

### 2.6 Guarantee and liability

Guarantee and liability claims are excluded for personal injury and material damage in case of

- Ignoring the information on transport and storage
- Improper use (misuse)
- Improper or neglected maintenance and repair
- Improper assembly / disassembly or improper operation
- Operation of the lubricator when safety devices and equipment are defective
- Operation of a heavily soiled lubricator
- Modifications or reconstructions that have been executed without written approval of **WITTENSTEIN alpha GmbH**

## 2.7 General safety instructions

	<p style="text-align: center;"><b>⚠ CAUTION</b></p> <p><b>Contact with leaking lubricant can irritate the skin and mucous membranes.</b></p> <ul style="list-style-type: none"><li>• Wear protective gloves, clothing and goggles.</li></ul>
	<p style="text-align: center;"><b>NOTICE</b></p> <p><b>Many electronic components are sensitive against electrostatic discharge (ESD).</b></p> <ul style="list-style-type: none"><li>• Work with ESD-suited work equipment.</li><li>• Never touch the components by their connections or feed lines.</li></ul>
	<p><b>Solvents can pollute soil and water.</b></p> <ul style="list-style-type: none"><li>• Use and dispose of cleaning solvents appropriately.</li></ul>



### 3 Description of the lubricator

The lubricator is an electronically controller lubrication device that is driven electro-chemically and supplies lubrication points automatically with lubricant. The grease cup is connected by a plastic hose to a felt pinion / lubrication point. After setting the lubricator, the lubricant is emitted automatically for a specified period while conforming to permitted specifications.

The lubricator is available in two sizes:

- Type 125
- Type 475

#### 3.1 Functional principle of the lubricator

When the lubricator is switched on, an electro-chemical reaction is triggered by the closing of contacts. Nitrogen is created as an intermediate product that leads to an increase of pressure in the nitrogen chamber. This pressure is forwarded through a bellows to the piston. The piston displaces the lubricant and the lubrication is initiated. A control light (LED) is located on the top of the lubricator, which flashes in regular intervals during fault-free operation.

#### 3.2 Overview of the lubricator components

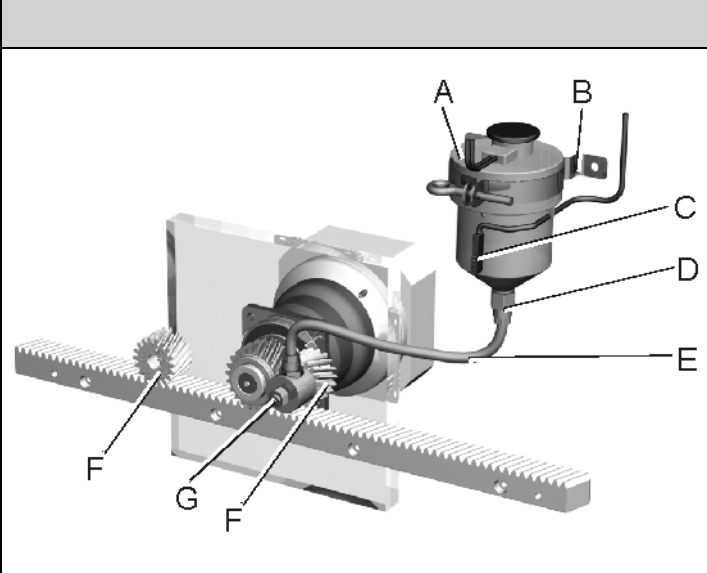
		Lubrication system structure
	A	Lubricator (grease cup)
	B	Pipe clamp
	C	Magnetic field sensor for detecting the end position
	D	Hose screw connection, aluminum
	E	Plastic hose, filled, 2 m
	F	Felt pinions for gearwheels/steering rack, on right/left
	G	Fastening axis with threaded tenon

Tbl-1: Overview of the lubrication system

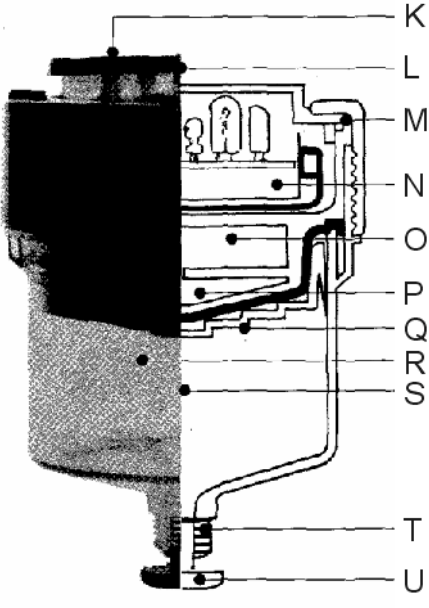
		Lubricator structure (A)
	K	Protective cover with bayonet coupling
	L	DIP switch
	M	Electronic circuit
	N	Battery chamber
	O	Nitrogen chamber
	P	Electro-pneumatic pressure generation
	Q	Piston
	R	Press
	S	Lubricant container
	T	Thread
	U	Plug
		Control light (LED)
		Water-repellant protective cover (only type 125)

Tbl-2: Overview of the lubricator

### 3.3 Type plate

The type plates are attached to the lubricator.

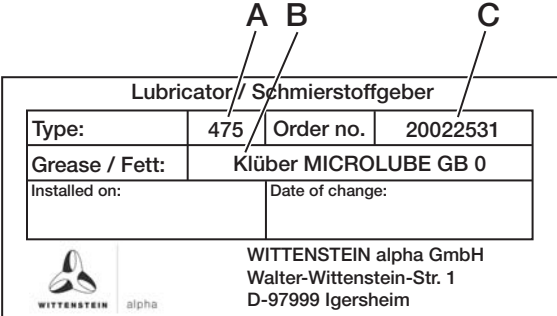
		Designation
	A	Lubricator type
	B	Lubricant
	C	Article number

Tbl-3: Type plate (sample values)

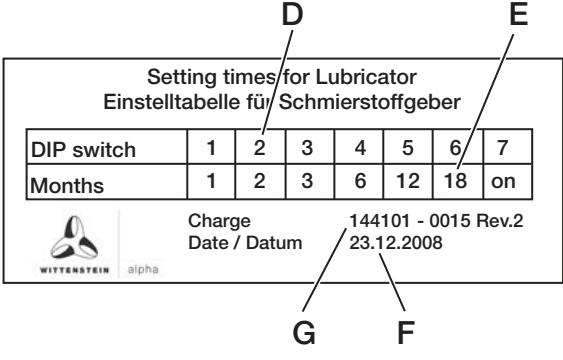
		Designation	
	D	DIP switch	
	E	Lubrication duration	
	F	Filling date	
	G	Batch number	

Tbl-4: Setting table for lubricator (sample values)

### 3.4 Notes on the lubricant used

	<p>All lubricators are prefilled with grease in the factory (see type plate).</p> <ul style="list-style-type: none"> <li>Observe the safety data sheets for the lubricant.</li> </ul>
---	---

You can receive further information on the lubricant directly from the manufacturer:

Klüber Lubrication München KG, Munich

Tel.: + 49 89 7876–0

[www.klueber.de](http://www.klueber.de)

### 3.5 Notes on the employed batteries

	<p>Batteries are pre-installed in all lubricators.</p> <ul style="list-style-type: none"> <li>Observe the safety data sheets for the batteries.</li> </ul>
---	--

You can receive further information on the batteries directly from the manufacturer:

[www.varta.de](http://www.varta.de)

### 3.6 Technical specifications

#### 3.6.1 Technical specifications of the lubricator

	Type 125	Type 475
<b>Contents</b>	100 cm <sup>3</sup>	460 cm <sup>3</sup>
<b>Dimensions: Height x Ø</b>	100 x 80 mm	150 x 115 mm
<b>Connection thread</b>	G ¼"	G ½"
<b>Lubrication duration / Setting range</b>	14 days to 18 months	
<b>Weight</b>	370 g	1000 g
<b>Pressure</b>	0.2 – 3.0 bar	
<b>Temperature range</b>	+10 °C to +50 °C	
<b>Relative humidity</b>	30 % – 80 % not condensing	
<b>Lubricant (standard)</b>	Klüber MICROLUBE GB 0	
<b>Operating voltage</b>	3 V	3 V
<b>Protection class</b>	IP64	IP64
<b>Battery (standard)</b>	Varta Electric Power 4006	
<b>Battery capacity (80 % reserve)</b>	3000 mAh	6000 mAh

Tbl-5: Technical specifications of the lubricator

#### 3.6.2 Technical specifications magnetic field sensor

	Magnetic field sensor (PNP closer)
<b>Measurement switching field strength <math>H_n</math></b>	1.2kA/m
<b>Secured switching field strength <math>H_a</math></b>	≥   2 kA/m
<b>Hysteresis H</b>	≤ 45% of $H_n$
<b>Temperature drift of the switch-on point</b>	≤ 0.3 %/°C
<b>Ambient temperature <math>T_a</math></b>	-25...+70 °C
<b>Use category</b>	DC 13
<b>Operational voltage <math>U_B</math></b>	10...30 V DC
<b>Line voltage drop <math>U_d</math> at <math>I_e &lt; 100</math> mA</b>	≤ 3.1 V
<b>Measurement insulation voltage <math>U_i</math></b>	75 V DC
<b>Measurement operational current <math>I_e</math></b>	200 mA
<b>Idle current <math>I_o</math> energized/de-energized</b>	≤ 30 mA/≤ 10 mA
<b>Residue current <math>I_r</math></b>	≤ 80 µA
<b>Protected against polarity reversal / Short-circuit proof</b>	Yes / Yes
<b>Permitted load capacity</b>	≤ 1 µF
<b>Protection type acc. IEC 529</b>	IP67
<b>Housing material</b>	LCP
<b>Connection type</b>	Cable
<b>Number of wires x wire cross-section</b>	3 x 0.14 mm <sup>2</sup>

Tbl-6: Technical specifications magnetic field sensor

## 4 Transport and storage

### 4.1 Scope of delivery

- Check the completeness of the delivery against the delivery note.
  - ① Missing parts or damage must be notified immediately in writing to the carrier, the insurance, or **WITTENSTEIN alpha GmbH**.

### 4.2 Packaging

The lubricator is delivered packed in foil and cardboard boxes.

- Dispose of the packaging materials at recycling sites intended for that. Observe the locally valid regulations for disposals.

### 4.3 Transport

	NOTICE
	<p><b>Hard knocks, for instance because of falling or hard dropping, can damage the lubricator.</b></p> <ul style="list-style-type: none"> <li>• Lower the lubricator slowly.</li> </ul>

### 4.4 Storage

	NOTICE
	<p><b>Improper storage can cause lubricant to leak.</b></p> <ul style="list-style-type: none"> <li>• Store the lubricator with the drain opening pointed downwards.</li> <li>• Check the lubricator for leaks before putting it into storage.</li> <li>• Stacking and improper storage can cause lubricator to malfunction.</li> </ul>

	NOTICE
	<p><b>Incompatible with oxidizing agents.</b></p> <ul style="list-style-type: none"> <li>• Do not store the lubricator together with oxidizing agents.</li> </ul>

Store the lubricator at a temperature of 0 °C to +20 °C and a relative humidity of 30 % to 60 % (not condensing) in the original packaging. Avoid direct sun radiation. Store the lubricator for no more than two years after the filling date (see type plate)

For storage logistics, we recommend the "first in – first out" method.

Please consult our Customer Service Department if you store lubricators with special lubricants.

## 5 Assembly

- Before you begin working, inform yourself of the general safety instructions (see Chapter 2.7 "General safety instructions").

### 5.1 Preparations

	NOTICE
	<p><b>Pressurized air can damage the lubricator seals.</b></p> <ul style="list-style-type: none"> <li>• Do not use pressurized air to clean the lubricator.</li> </ul>

- Clean the lubrication point using a clean, lint-free cloth.
- Clean lubricator externally with just a little pressure. Use only antistatic cloths for the cleaning.
- Oil the lubrication point with a grease gun.
- Check the lubricator and the component additionally for damage and impurities.
- If you want to synchronize the lubricator with the machine running time, then you also need a potential free contact (closer) (see Chapter 5.3 "Synchronization with the machine runtime").

### 5.2 Mounting the lubricator

	<ul style="list-style-type: none"> <li>• Avoid the formation of bubbles when assembling the filled plastic hoses and the lubricator.</li> </ul>
--	---

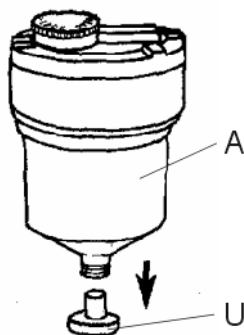



- Screw the supplied pipe clamp for fastening the lubricator to the machine.
  - ① Position the lubricator to a place that is easily accessed.
  - ① Installation dimension of the pipe clamp, see Chapter 9.3 "Installation dimensions pipe clamp for lubricator", table "Tbl-14".
- Remove the unfilled ends of the plastic hose.
- Mount the hose connections to the filled plastic hose.
- Mount the fastening axis and the felt pinion on the lubrication point.
- Screw the plastic hose onto the fastening axis.
- Place the lubricator into the pipe clamp and tighten the clamping bolt by hand.
- Pull out the fiber concrete plug (U) of the lubricator (A).
- Connect the plastic hose to the lubricator.

### 5.3 Synchronization with the machine runtime

A synchronization with the machine runtime is recommended for machines that have idle times of at least one week up to machines with a maximum idles time of 6 months.

There are two contact cables with angle plugs located on the lubricator. No extra power supply is needed for the installation.

	<p style="text-align: center;"><b>NOTICE</b></p> <p><b>Faulty electrical connections can damage the lubricator.</b></p> <ul style="list-style-type: none"> <li>• Have all electrical connection work performed by qualified technicians only.</li> <li>• Do not use external power supplies for the installation of the lubricator.</li> </ul>
	<p style="text-align: center;"><b>NOTICE</b></p> <p><b>Many electronic components are sensitive against electrostatic discharge (ESD).</b></p> <ul style="list-style-type: none"> <li>• To avoid electrostatic discharge on the electronic components of the lubricator, we recommend using screened contact cables.</li> <li>• Strong electric motors, magnets or other possible interference factors should not be in the direct vicinity to the contact cables.</li> </ul>

#### 5.3.1 Employing the lubricator with synchronization

- On the lubricator type 475, remove the contact bridge at the nuts and fasten the contact cables.
- If necessary, extend the contact cables for the lubricator type 125.

The length of the contact cables between lubricator and machine may not be longer than 5 meters.

- Connect the contact cables to a potential-free contact.

#### 5.3.2 Employing the lubricator without synchronization

The lubricator can also be employed without synchronization with a contact bridge. On the lubricator type 475, both contacts are short circuited by default.

- Twist (short circuit) both contact cables with each other on the lubricator type 125.

**5.4 Installation of the magnetic field sensor for detecting the end position**

The magnetic field sensor queries the position of the piston and emits the status signal „empty“ from the lubricator to a signaling device (e.g. signal lamp, loudspeaker) or to the controller. When the status message „empty,“ is given, then there are only about 5 % lubricant left in the lubricator's reserve.

Pin	Color	Connection
<b>Bu</b>	Blue	- (negative) supply voltage, 10–30 V DC (direct current)
<b>Bn</b>	Brown	+ (positive) supply voltage, 10–30 V DC (direct current)
<b>Bl</b>	Black	Output (positive)

Tbl-7: Connection assignment for magnetic field sensor

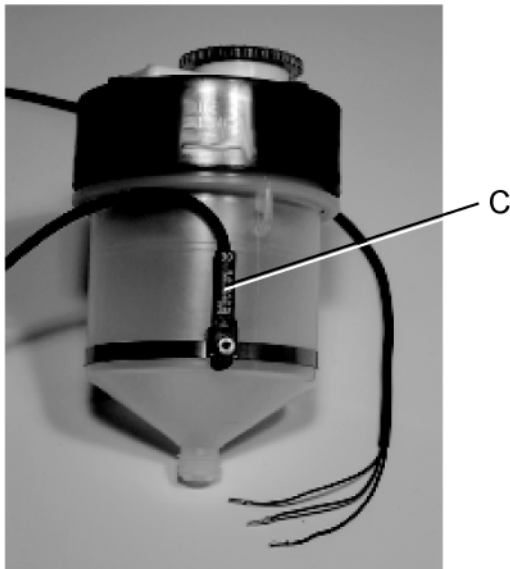

A signal lamp or a relay winding for example can be connected between pin Bk (black) and pin Bu (blue). If the connector is closed, then the + (positive) signal of the power voltage is applied at pin Bk (black), max. possible current of 200 mA at 30 V supply voltage. In this case for example, the signal lamp or the relay winding between pin Bk (black) and pin Bu (blue) would receive current, which would cause the signal lamp to light up or the relay to draw.

When connecting a relay, a protective diode should be mounted over the relay winding so that the inductive voltage that is induced in the relay in the drop-off mode can be short-circuited and thus cannot destroy the switch.



## 6 Startup and operation

- Before you begin working, inform yourself of the general safety instructions (see Chapter 2.7 "General safety instructions").

	<p><b>Improper use can cause damage to the lubricator.</b></p> <ul style="list-style-type: none"> <li>• Make sure that the ambient temperature does not drop below +10 °C or exceed +50 °C.</li> <li>• For other conditions of use, please consult our Customer Service Department.</li> </ul>
--	--

### 6.1 Activating the lubricator

Overview of the DIP switches of the lubricator:

- 1 – 6 Day/Month setting
- 7 On/Off lubricator

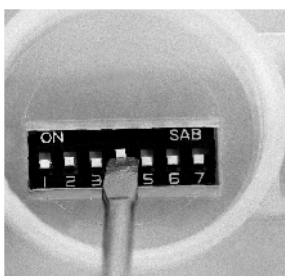
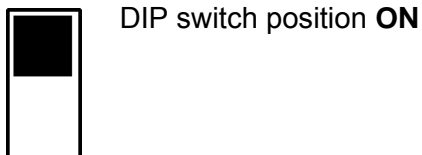
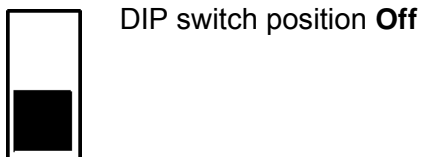
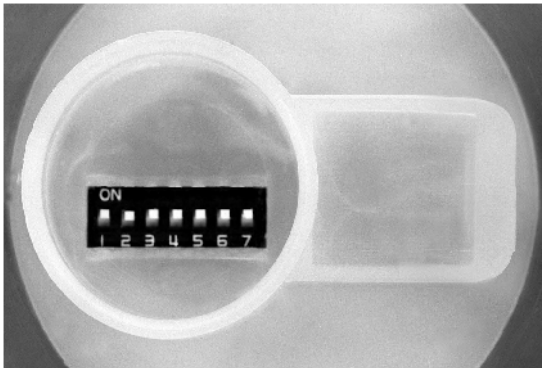

- Take off the protective cover of the lubricator (bayonet coupling).
- Set all DIP switches to ON.
  - ➔ The control light on the top of the lubricator flashes in regular intervals.
  - ➔ The pressure build-up is started. The pressure build-up time is about 6 – 8 hours.
- As soon as lubricant is emitted, set the DIP switches 1 – 6 to OFF. DIP switch 7 stays at ON.
  - ➔ The control light on the top of the lubricator flashes in regular intervals.

## 6.2 Setting the lubrication duration

- Note that the lubrication duration can deviate with special lubricants.



The amount and duration of the lubrication can be changed at any time, even during the running operation. Simply set the desired DIP switch combination or change existing settings.

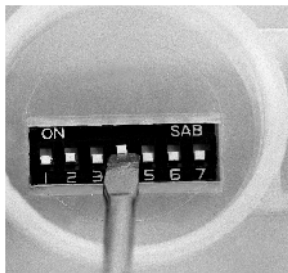

- Set the desired lubrication duration by the appropriate combination of the DIP switches 1 – 6 to ON.
  - You can find the setting combinations in Chapter 9.1 "Setting combinations for lubricator", table "Tbl-10".
  - The control light on the top of the lubricator flashes in regular intervals.
  - The lubricator is now active.
- Place the protective cover on the lubricator.

## 6.3 Restarting after a shutdown

The established pressure remains for about five days. The soiling starts up with a slight delay after a renewed start of the lubricator.

- Set the DIP switch 7 to ON.
  - The control light on the top of the lubricator flashes in regular intervals.
- If necessary readjust the lubrication duration, see Chapter 6.2 "Setting the lubrication duration".

## 7 Maintenance and disposal

- Before you begin working, inform yourself of the general safety instructions (see Chapter 2.7 "General safety instructions").

### 7.1 Maintenance work

#### 7.1.1 Visual inspection

- Check the entire lubricator and all cables for exterior damage.
- Make sure that no foreign medium (e.g. water) can get into the lubricator.
- Check the lubricant level and the function of the lubricator.

#### 7.1.2 Cleaning

The lubricator may not get into contact with aggressive solvents or cleansers.

- Clean lubricator externally with just a little pressure. Use only antistatic cloths for the cleaning.

### 7.2 Maintenance schedule

Maintenance work	At startup	After 500 operating hours or 3 months	Every 3 months
Visual inspection	X	X	X
Cleaning		X	X

Tbl-8: Maintenance schedule

### 7.3 Replacing the lubricator

- ① The order number for the replacement lubricator can be found in Chapter 9.4 "Spare parts list", table "Tbl-15".

	NOTICE
	<p><b>Faulty electrical connections can damage the lubricator.</b></p> <ul style="list-style-type: none"> <li>• Have all electrical connection work performed by qualified technicians only.</li> </ul>

- Disconnect the machine from the mains before replacing the lubricator.
- Set all DIP switches to OFF.
- Remove if necessary the contact cables for the synchronization from the machine.
- Remove the hose screw connection from the lubricator.
- Close the drain opening of the lubricator.
- Remove the magnetic field sensor from the lubricator.
- Loosen the clamping bolt of the pipe clamp and remove the lubricator.
  - ① Information on disposing of the old lubricator can be found in Chapter 7.4 "Disposing of the lubricator".
- Place the replacement lubricator into the pipe clamp and tighten the clamping bolt by hand.
- Place the magnetic field sensor on the replacement lubricator at the same level as on the old lubricator.

- Pull out the fiber concrete plug of the lubricator.
- Connect the plastic hose to the lubricator.
- Connect if necessary the contact cables for the synchronization with the machine running time to the machine.
  - ① Information on connecting the contact cables can be found in Chapter 5.3 "Synchronization with the machine runtime".
- Activate the lubricator.
  - ① Information on activating the lubricator can be found in Chapter 6.2 "Setting the lubrication duration".

#### 7.4 Disposing of the lubricator



**Lubricants (oils and greases) can pollute soil and water.**

- Use and dispose of lubricants appropriately.

If you have any questions regarding ecological disposal methods, please consult our Customer Service.

If our product is no longer of use and you wish to dispose of it, refer to the instructions here.

- Observe the locally valid regulations for disposals.

You should pay attention to the following residual substances and materials:

- **Lubricants:** Do not mix polyglycols with mineral oils that are meant for recycling.
- **Batteries:** Do not recharge batteries.

## 8 Malfunctions

	NOTICE
	<p><b>A changed operational behavior can be an indication for an existing damage of the lubricator or cause a damage of the lubricator.</b></p> <ul style="list-style-type: none"> <li>Do not put the lubricator back into operation until the cause of the malfunction has been rectified.</li> </ul>

Fault	Possible cause	Solution
No lubricant is emitted, control light does not flash.	Lubricator is not switched on	Activate the lubricator.
	Batteries are discharged.	Please consult our Customer Service Department.
	Control board is damaged.	Please consult our Customer Service Department.
No lubricant is emitted, control light flashes.	DIP switches not activated.	Set duration of lubrication.
	No more lubricant.	Replace lubricator.
	Lubrication point is blocked.	Oil the lubrication point with the grease gun or clean it.
	Lubricator is defective.	Replace lubricator.
	Synchronization cable is not connected (bridged)	Connect synchronization cable according to instructions.
Water in the plastic cover.	Build up of condensation water	Please consult our Customer Service Department.
	Aggressive cleaning by pressurized air blaster	Please consult our Customer Service Department.
Lubricant is emptied in shortest time	DIP switch combination is set wrong.	Correct DIP switch combination according to instructions.
Grease level does not reduce.	Lubrication point is blocked.	Oil the lubrication point with the grease gun or clean it.
	DIP switches not activated.	Activate the desired DIP switch combination.
Control light is lit constantly	Lubricator is defective.	Replace lubricator.

Tbl-9: Malfunctions

## 9 Appendix

### 9.1 Setting combinations for lubricator

DIP switch position	Lubricant quantity daily [cm <sup>3</sup> ]		Lubrication duration	
	Type 125	Type 475	Months	Days
7	DIP switch for activation (ON) of the lubricator. Control light flashes in regular intervals.			
6	0.175	0.60	18	-
5	0.35	1.20	12	-
4	0.70	2.50	6	-
3	1.30	4.50	3	-
2	2.10	7.50	2	-
1	4.00	14.00	1	-
All DIP switches are activated	9.00	34.00	-	14
<b>Additional setting information</b>				
5 + 4	1.05	3.50	-	121
5 + 3	1.74	6.00	-	71
4 + 3	2.08	7.30	-	57
5 + 4 + 3	2.35	8.50	-	51
5 + 2	2.45	8.50	-	52
4 + 2	2.60	9.10	-	45
3 + 2	3.48	12.20	-	35
5 + 3 + 2	3.83	13.40	-	28
4 + 3 + 2	4.16	14.50	-	30
5 + 4 + 3 + 2	4.53	15.80	-	27
4 + 1	4.80	16.80	-	24
3 + 1	5.56	19.50	-	23.5
2 + 1	6.26	22.00	-	20
5 + 2 + 1	6.61	23.10	-	19
3 + 2 + 1	7.65	26.80	-	17
5 + 3 + 2 + 1	8.00	28.00	-	16
4 + 3 + 2 + 1	8.33	30.00	-	15
5 + 4 + 3 + 2 + 1	8.70	30.50	-	14.5

Tbl-10: Setting combinations for lubricator

## 9.2 Lubrication aids

### 9.2.1 Lubrication aid I for type 125

Setting time lubricator [days]	Lubricant consumption daily [cm <sup>3</sup> ]	Grease gun strokes daily
30	4	4
60	2.1	2
90	1.3	1.3
180	0.7	1/2
360	0.35	1/3

Tbl-11: Conversion of lubricant consumption of lubricator and grease gun

### 9.2.2 Lubrication aid II for type 125

	Grease gun strokes	Setting time lubricator [days]
Daily	3 - 4	30
Every 2 – 3 days	3 - 4	60
Weekly	8 - 10	90
Every 14 days	8 - 10	180
Monthly	8 - 10	360

Tbl-12: Conversion of lubricant consumption of grease gun to lubricator

### 9.2.3 Lubrication aid III

Depending on the application conditions, you can set the lubricator to various drainage times (14 days to 18 months) by means of the DIP switches.

Our recommendation for constant drive velocity at 90 m/min:

For example Module 2: 0.175 to 0.35 cm<sup>3</sup>/day or Module 3: 0.35 to 0.7 cm<sup>3</sup>/day (18M or 12M)

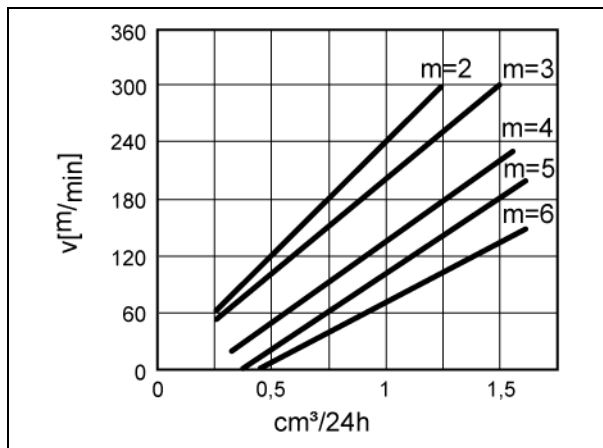

Tbl-13: Lubricant dosing for felt pinion lubrication

9.3 Installation dimensions pipe clamp for lubricator

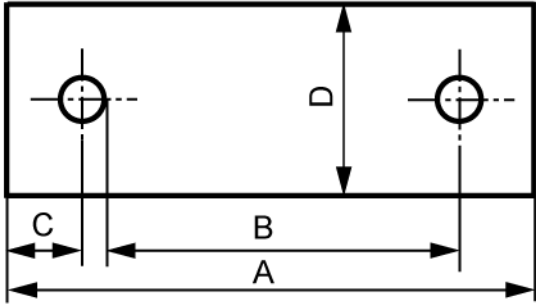
		Type 125	Type 475
	A [mm]	112	128
	B [mm]	95	105
	C [mm]	6.5	8.5
	D [mm]	16	25
			

Tbl-14: Installation dimensions of pipe clamp

9.4 Spare parts list

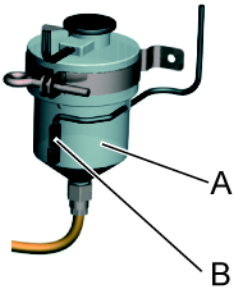
		Title	Order number	
			Type 125	Type 475
	A	Replacement lubricator*	20021556	20022533
	B	Replacement magnetic field sensor	20021557	20022535
	C	Grease cup kit	20021555	20022531
<p>* without plastic hose, magnetic field sensor kit, pipe clamp, hose screw connection, and synchronization cable</p>				

Tbl-15: Spare parts list for lubricator





alpha

WITTENSTEIN alpha GmbH  
Walter-Wittenstein-Straße 1  
97999 Igersheim

**WITTENSTEIN - being one with the future**

**[www.wittenstein.de](http://www.wittenstein.de)**