

# Motoranbauanleitung

Motormounting instructions

Assemblage moteur

Istruzioni di montaggio per motori

Instrucciones para el montaje del motor

Instruções para montagem do motor

## Vor Inbetriebnahme Betriebsanleitung lesen!

Read before operating unit!

Avant mise en service, lisez la notice de service!

Prima della messa in funzione leggere le istruzioni!

Leer antes de manejar el equipo!

Leia antes de colocar em funcionamento!

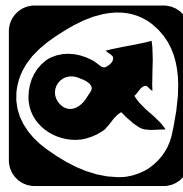

**alpha**

alpha getriebebau GmbH  
Walter-Wittenstein-Str.1  
D-97999 Igersheim  
Tel. +49(0)700/493-10020  
Fax +49(0)7931/493-200  
service@alphagetriebe.de  
www.alphagetriebe.de

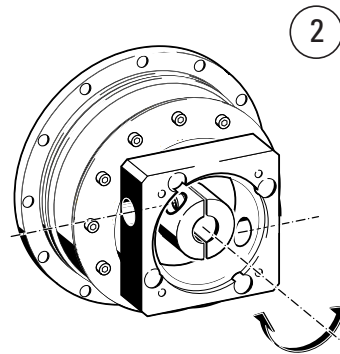
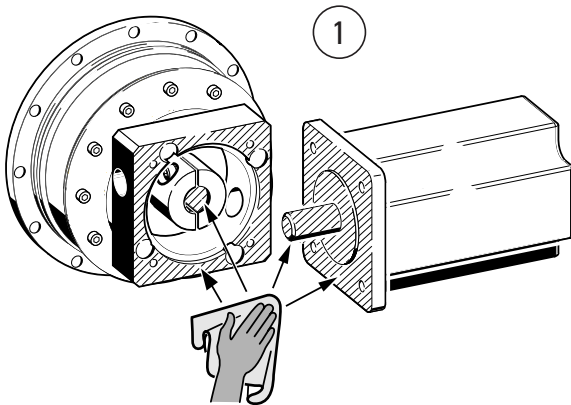
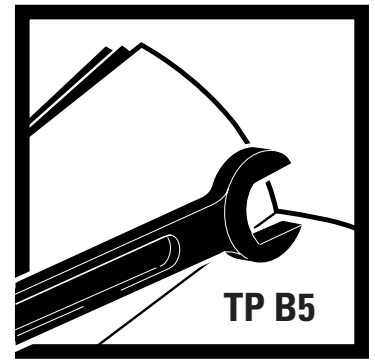

2. Lagerichtig drehen
2. Turn to align holes with set-screws
2. Tourner en position correcte
2. Girare in posizione corretta
2. Girar para alinear los agujeros con los tornillos
2. Girar até alinhar os furos com os parafusos

TP 004 - TP 110

TP 300 + TP 500

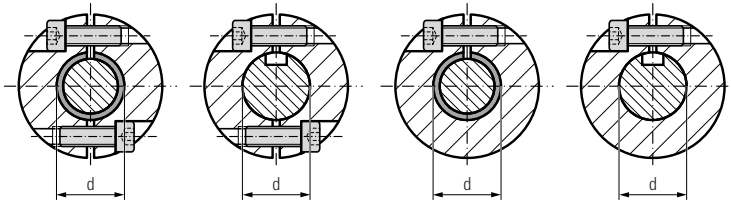

- d... Klemmnabennendurchmesser  
d... Clamping hub bore diameter  
d... Alesage de l'accouplement  
d... Diametro interno cannotta/morsetto  
d... Casquillo adaptador de diametro  
d... Diâmetro interno do anel de contração

3

3. Wenn Distanzhülse und/oder Nut, dann lagerichtig montieren. Paßfeder entfernen.
3. If bushing or keyway, mount in proper position. Remove key.
3. Tourner en position correcte en cas de bague ou rainure de clavette. Retirer la clavette.
3. In caso di bussola distanziale e/o cava per chiavetta, montare in posizione corretta. Togliere la chiavetta.
3. Si se utiliza casquillo o chavetero, montar en la posición adecuada. Sacar la chaveta.
3. Se for utilizada bucha redutora ou se o eixo tiver rasgo de chaveta, montar na posição adequada. Retirar a chaveta.

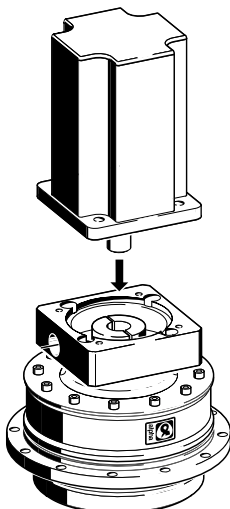

- a = vertikal – Bevorzugte Methode**  
**a = vertical – preferred method**  
**a = vertical – méthode conseillée**  
**a = verticale – metodo preferenziale**  
**a = vertical – método preferible**  
**a = vertical – método preferível**

- b = horizontal  
b = horizontal  
b = horizontal  
b = orizzontale  
b = horizontale  
b = horizontale

4b

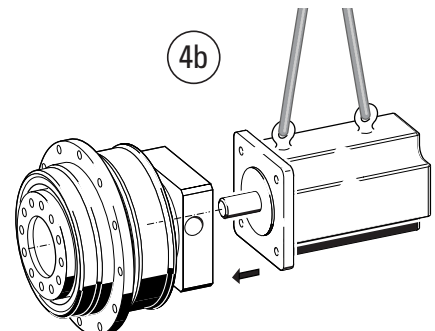

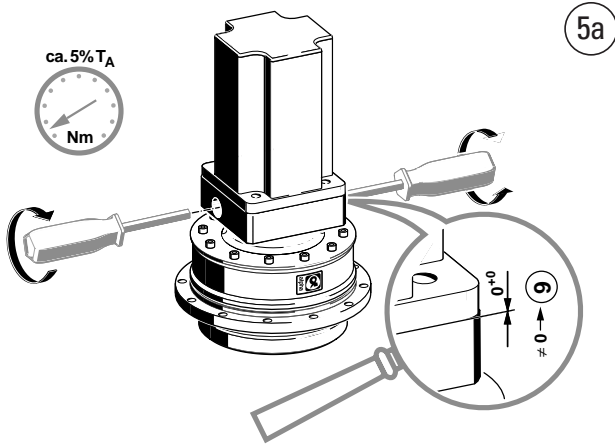

5a

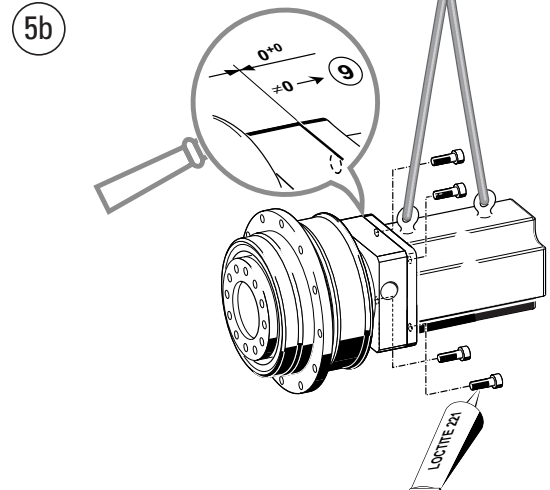

5b

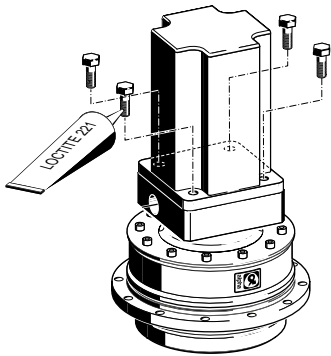

6a

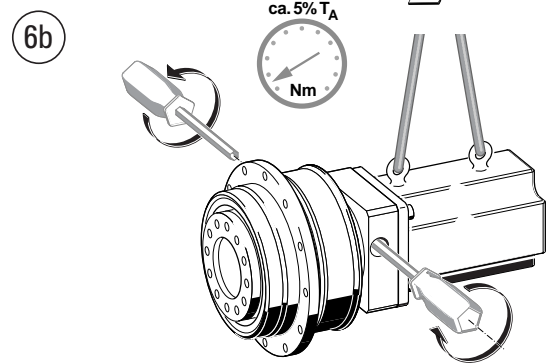

6b

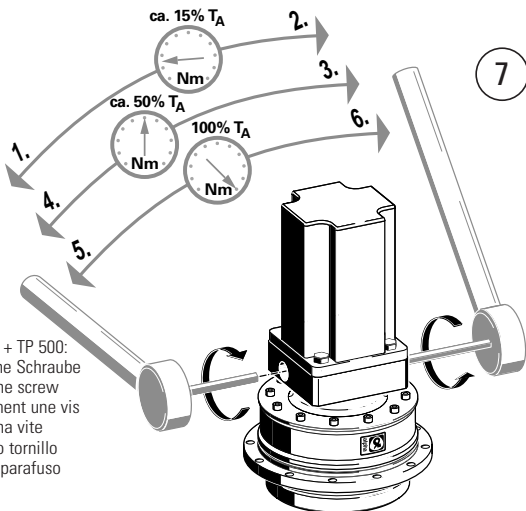

7

Bei TP 300 + TP 500:  
Nur eine Schraube  
Only one screw  
Seulement une vis  
Solo una vite  
Um solo tornillo  
Só um parafuso

Bündig  
Flush (press in to  
leave no ridge)  
Affleurant  
Livellati senza  
Sporgenze  
Presionar para  
que quede al  
mismo nivel  
Pressiona até  
atingir o  
mesmo nivel

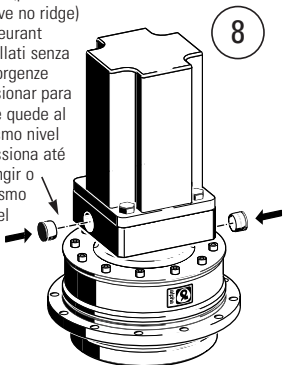

8

Achtung: In diesen Fällen in Betriebsanleitung nachlesen!  
Note: In these cases reread operating instructions!  
Attention: Dans ce cas, lire la notice de service!  
Attenzione: In questi casi leggere, nelle istruzioni!  
Nota: En estos casos releer las instrucciones de funcionamiento!  
Atenção: Nestes casos, releer as instruções de funcionamento!

9

Größe Size Taille Grandezza Tamaño Tamanho	Getriebestufen Gear stages Nombre d' étage Stadi del riduttore Etapas Estágios	Klemmnabeninnen Ø siehe ③ Clamping hub bore Ø Alesage de l'acouplement Ø interno canotto/morsetto Casquillo adaptador de Ø Ø interno do anel de contração [mm]	Schlüsselweite Width across flats Côte sur plats Misura delle chiavi Distância entre caras Distância entre faces [mm]	Anzugsmoment Tightening torque Couple de serrage Coppia di serraggio Par de apriete Torque de aperto T <sub>A</sub> [Nm]
TP 004	1	≤14	3	5
	2	≤11	3	5
TP 010	1	≤19	4	9,5
	2	≤11	3	5,0
TP 025	1	>11 ≤14	3	5,0
		≤14	4	9,5
		>14 ≤19	5	16,0
		>19 ≤28	6	39,0
TP 050	1	>28 ≤32	8	77,0
		≤14	3	5,0
TP 110	1	>14 ≤19	4	9,5
		≤19	5	16,0
		>19 ≤24	6	39,0
		>24 ≤38	8	77,0
TP 300	2	≤19	4	9,5
		>19 ≤32	6	39,0
		≤14	5	16,0
		>14 ≤19	6	39,0
TP 500	2	>19 ≤24	8	65,0
		>24 ≤48	10	115,0

