



Screwdriving technology

Automation

Air motors

Air tools

DEPRAG

Screwdriver Spindles
pneumatic

NANOMAT Control Screwdrivers

The Screwdriver for your micro assemblies

straight design - torque from 8 Nmm - 300 Nmm
(1.14 in.oz to 42.6 in.oz)

- top precision shut-off clutch
- for small spaces
- long-life, robust

The particular strength of a NANOMAT control screwdriver in straight design is that it can carry out screw assemblies with torque ranges of 8 Nmm to 300 Nmm.

In these ranges you can not only assemble screws but also adjust them.

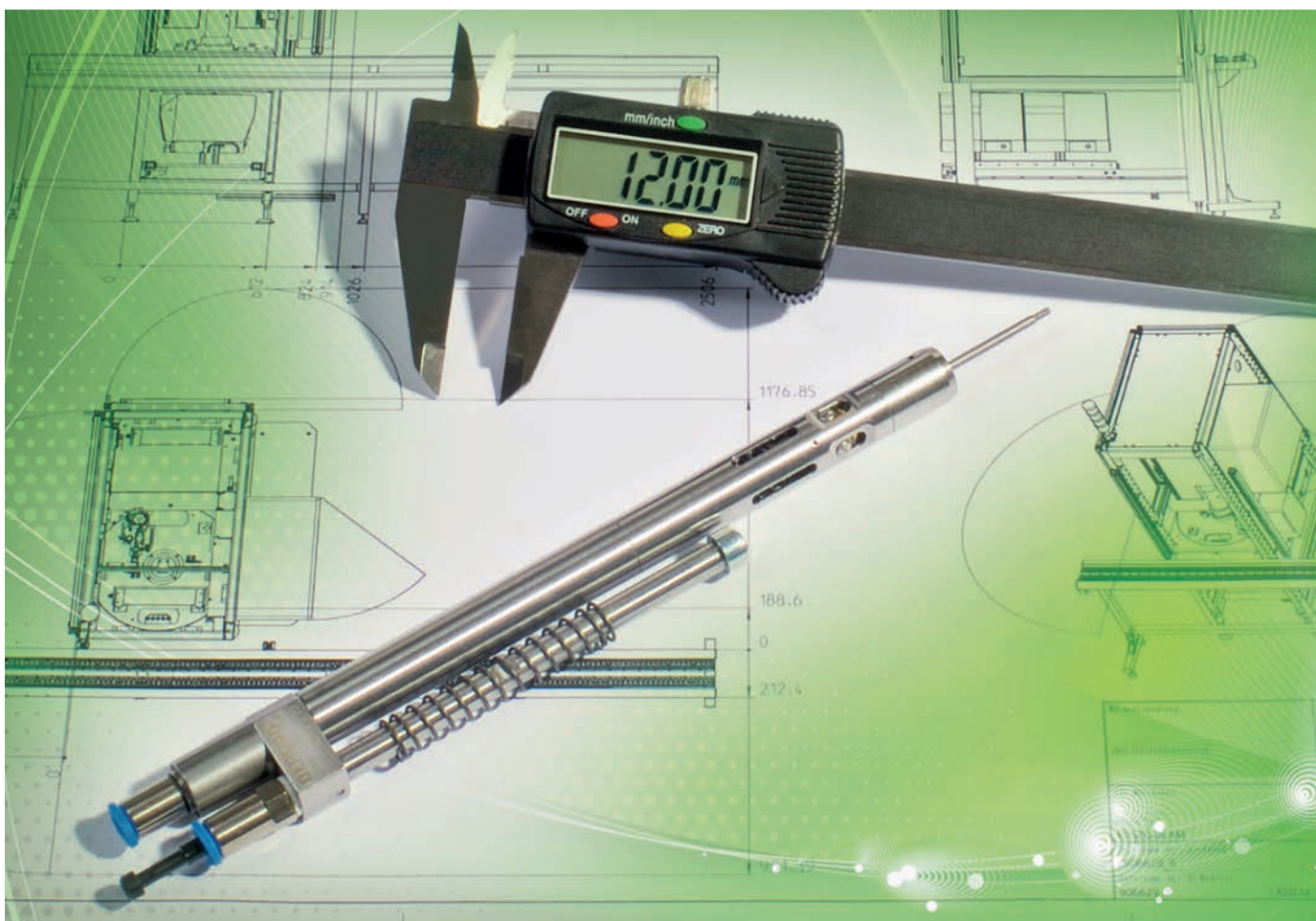

NANOMAT Control Screwdrivers

The ergonomic NANOMAT screwdriver is extremely durable due to its extraordinary processing quality and design for heavy industrial use.

The NANOMAT clutch works with the tried and tested principle of a mechanical disengagement and shut-off clutch.

This extremely accurate shut-off clutch allows torque precision of $< \pm 3\%$ standard deviation, which is maintained for millions of assemblies.

When used under the correct conditions DEPRAG pneumatic screwdrivers with shutoff clutch conform with a Cmk value of ≥ 1.67 with a tolerance requirement of $\pm 10\%$ in relation to 6 Sigma according to ISO 5393.

In other words a Cmk value of 1.67 means that there is a failure rate of 0.6 per million screw assemblies.

The NANOMAT spindles can be easily integrated and are extremely small. Control screwdrivers are available in right rotation, left rotation or reversible, with push to start or remote start option.

These tools can be used without lubrication: This should however only be done in specific applications. Using a tool without lubrication will decrease its lifespan.

ADVANTAGES

Smallest possible screwdriver spindle spacing:

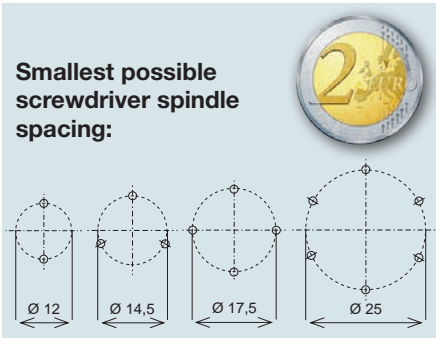

- **Accommodates standard bits type A3 according to DIN ISO 1173**
The advantage is the use of standard bits.
- **Integrated Quick Change Chuck**
Bit change without the use of tools, quickly and easily.
- **Externally adjustable clutch mechanism**
The torque can be adjusted quickly and conveniently without the need for special tools.
- **High precision shut-off clutch**
The high precision torque control is

based on the long standing DEPRAG principle of mechanical disengagement and motor shut-off.

- **Standardised ultra slim design**
Only 12 mm diameter for the tightest screw CL distance in your stationary application.
- **Standard overall length**
All gearing versions and models are available in a single length for ease of integration.
- **Proven DEPRAG guide bolt system**
Optimised end-load pressure on the screw, via adjustable spring force.

APPLICATIONS



- Medical technology - assembly of hearing aids or cardiac pacemakers
- The watchmaking industry
- The optical industry - assembly of eyeglasses, lenses, photography equipment or microscopes
- Manufacture of small consumer electronic devices - Mobile phones, calculators, portable game consoles, Laptops and tablet PC's
- Precision engineering – gauges

TECHNICAL DATA

Screwdriver Style		Motor Size 00			
Spindle right rotation, right shut-off Push to Start	Type Part no.	345-3008-31 204000 C	345-5008-31 204000 E	345-6008-31 204000 F	345-7008-31 204000 G
Spindle left rotation, left shut-off Push to Start	Type Part no.	345-3008-31L 204001 C	345-5008-31L 204001 E	345-6008-31L 204001 F	345-7008-31L 204001 G
Spindle right rotation, right shut-off Remote Start	Type Part no.	345-3000-31 204004 C	345-5000-31 204004 E	345-6000-31 204004 F	345-7000-31 204004 G
Spindle left rotation, left shut-off Remote Start	Type Part no.	345-3000-31L 204005 C	345-5000-31L 204005 E	345-6000-31L 204005 F	345-7000-31L 204005 G
Torque min.	Ncm / in.oz	1 / 1.42	0.8 / 1.14	0.8 / 1.14	0.8 / 1.14
Torque max.	Ncm / in.oz	15 / 21.3	25 / 35.5	30 / 42.6	30 / 42.6
Speed, idling	rpm	1600	775	590	340
Air consumption	m ³ /min / cfm	0.1 / 3.5	0.1 / 3.5	0.1 / 3.5	0.1 / 3.5
Weight	kg / lbs	0.14 / 0.31	0.14 / 0.31	0.14 / 0.31	0.14 / 0.31
Push to Start pressure	N / lbs	3 / 0.67	3 / 0.67	3 / 0.67	3 / 0.67
Pressure at max. screwdriver stroke	N / lbs	20 / 4.48	20 / 4.48	20 / 4.48	20 / 4.48
Hose I.D. for air supply	mm / in.	2.5 / ³ / ₃₂	2.5 / ³ / ₃₂	2.5 / ³ / ₃₂	2.5 / ³ / ₃₂
Hose I.D. for function control	mm / in.	2.5 / ³ / ₃₂	2.5 / ³ / ₃₂	2.5 / ³ / ₃₂	2.5 / ³ / ₃₂
Internal hex. drive DIN ISO 1173		B3 (3 mm/.118")	B3 (3 mm/.118")	B3 (3 mm/.118")	B3 (3 mm/.118")
Suitable tool inserts and connecting components with a drive as per DIN ISO 1173		A3 (3 mm/.118")	A3 (3 mm/.118")	A3 (3 mm/.118")	A3 (3 mm/.118")
Spindle reversible, right shut-off, Push To Start for right rotation reverse by Remote Start	Type Part no.	345-3008-31U 204002 C	345-5008-31U 204002 E	345-6008-31U 204002 F	345-7008-31U 204002 G
Spindle reversible, left shut-off, Push To Start for left rotation reverse by Remote Start	Type Part no.	345-3008-31UL 204003 C	345-5008-31UL 204003 E	345-6008-31UL 204003 F	345-7008-31UL 204003 G
Spindle reversible, right shut-off, Remote Start in drive direction and in reverse	Type Part no.	345-3000-31U 204006 C	345-5000-31U 204006 E	345-6000-31U 204006 F	345-7000-31U 204006 G
Spindle reversible, left shut-off, Remote Start in drive direction and in reverse	Type Part no.	345-3000-31UL 204007 C	345-5000-31UL 204007 E	345-6000-31UL 204007 F	345-7000-31UL 204007 G
Torque min.	Ncm / in.oz	1 / 1.42	0.8 / 1.14	0.8 / 1.14	0.8 / 1.14
Torque max.	Ncm / in.oz	15 / 21.3	25 / 35.5	30 / 42.6	30 / 42.6
Speed, idling	rpm	1400	680	500	300
Air consumption	m ³ /min / cfm	0.1 / 3.5	0.1 / 3.5	0.1 / 3.5	0.1 / 3.5
Weight	kg / lbs	0.15 / 0.33	0.15 / 0.33	0.15 / 0.33	0.15 / 0.33
Push to Start pressure	N / lbs	3 / 0.67	3 / 0.67	3 / 0.67	3 / 0.67
Pressure at max. screwdriver stroke	N / lbs	20 / 4.48	20 / 4.48	20 / 4.48	20 / 4.48
Hose I.D. for air supply	mm / in.	2.5 / ³ / ₃₂	2.5 / ³ / ₃₂	2.5 / ³ / ₃₂	2.5 / ³ / ₃₂
Hose I.D. for function control	mm / in.	2.5 / ³ / ₃₂	2.5 / ³ / ₃₂	2.5 / ³ / ₃₂	2.5 / ³ / ₃₂
Internal hex. drive DIN ISO 1173		B3 (3 mm/.118")	B3 (3 mm/.118")	B3 (3 mm/.118")	B3 (3 mm/.118")
Suitable tool inserts and connecting components with a drive as per DIN ISO 1173		A3 (3 mm/.118")	A3 (3 mm/.118")	A3 (3 mm/.118")	A3 (3 mm/.118")

Performance data relate to an air pressure of 6.3 bar (90 PSI)

Standard Equipment:

Nipple (mounted) · Torque adjustment tool · Assortment of clutch springs

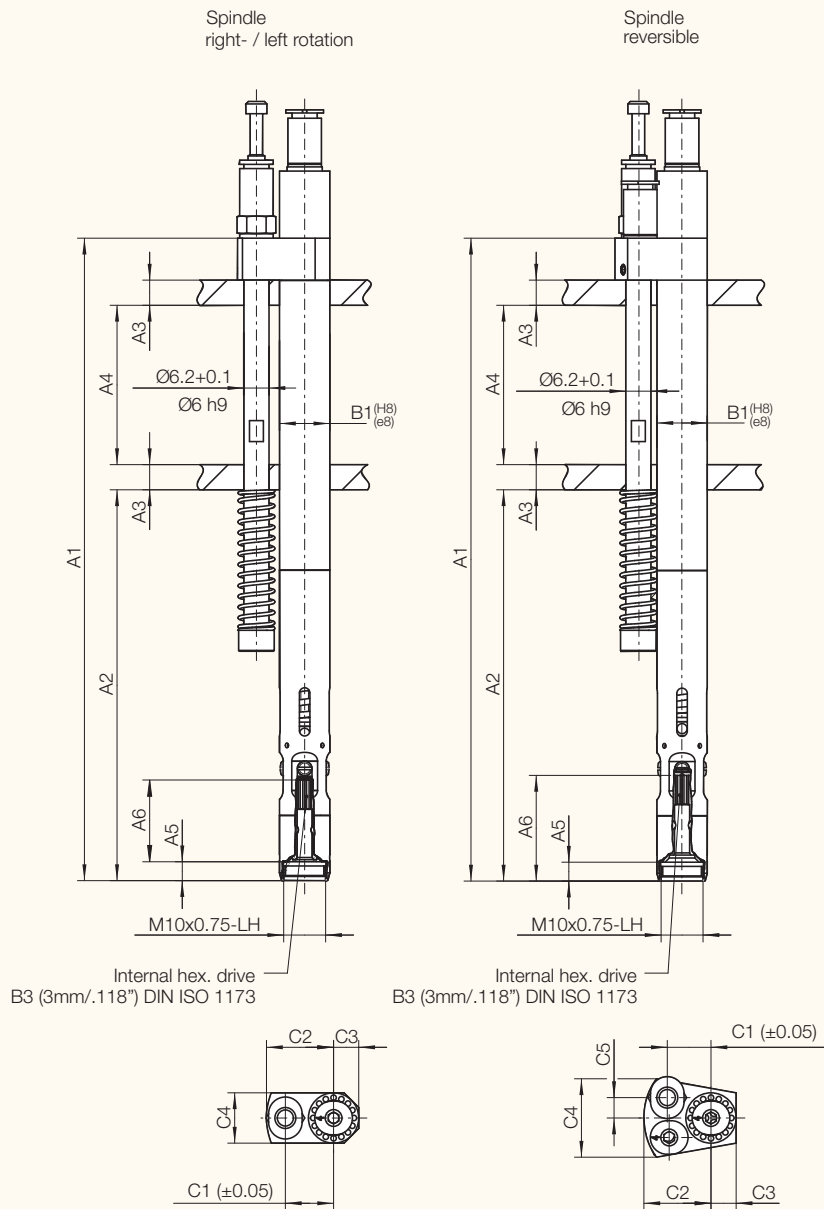

204835

Motor Size 00

Type				Dimensions (mm)											
				A1	A2	A3	A4	A5	A6	B1	C1	C2	C3	C4	C5
Spindle right- / left rotation															
345-3008-31	345-3008-31L	345-3000-31	345-3000-31L	153.2	93.2	6	38	4.5	25.2	12	11.5	16	6	12	-
345-5008-31	345-5008-31L	345-5000-31	345-5000-31L												
345-6008-31	345-6008-31L	345-6000-31	345-6000-31L												
345-7008-31	345-7008-31L	345-7000-31	345-7000-31L												
Spindle reversible															
345-3008-31U	345-3008-31UL	345-3000-31U	345-3000-31UL	153.3	93.3	6	38	4.5	25.2	12	10.4	16	6	18.7	4.9
345-5008-31U	345-5008-31UL	345-5000-31U	345-5000-31UL												
345-6008-31U	345-6008-31UL	345-6000-31U	345-6000-31UL												
345-7008-31U	345-7008-31UL	345-7000-31U	345-7000-31UL												

Optional Equipment

Spring sleeve cpl., with vacuum connection (Custom screw finder sleeve and bit combinations upon request. Vacuum screw holding accessories available.)	Part no.	203860 B
Exhaust connection vertical ¹⁾ , turnable	Part no.	386924 L

¹⁾ for corresponding exhaust filter / silencer (see leaflet D3340 E)

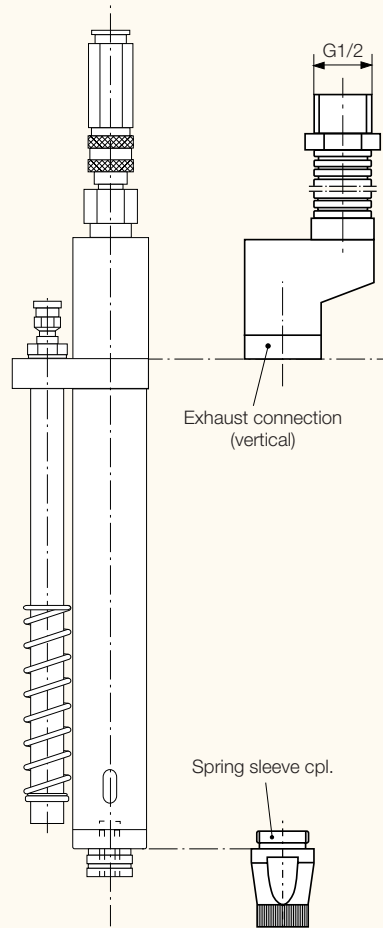

DEPRAG

DEPRAG SCHULZ GMBH u. CO.

P.O. Box 1352, D-92203 Amberg, Germany
Carl-Schulz-Platz 1, D-92224 Amberg
Phone (+49) 9621 371-0, Fax (+49) 9621 371-120
www.deprag.com
info@deprag.de



CERTIFIED AS PER DIN EN ISO 9001
